



Alpha







PNEUMATIC RACK & PINION ACTUATORS 90° - 120° - 180°

ALUMINIUM



COATINGS – MATERIAL TREATMENTS

| | AV | DESCRIPTION | | | | APPLICATION FIELD |
|--|-----------|---------------------------------------|---------------------------------------|-----------|---|--|
| | | Body | Covers | Pistons | Shaft | |
|  | standard | Hard Anodizing | Polyester painting | Anodizing | High phosphorous nickel-plating (12%) opt. AISI 316 (A4) | - Industry, general use. |
| | Colour | Dark gray | Several available | Brown | Polished steel | |
| | Thickness | 50 µ | 60/80 µ | 15 µ | 20 µ | |
| | NV | DESCRIPTION | | | | APPLICATION FIELD |
| | | Body | Covers | Pistons | Shaft | |
|  | | High phosphorous nickel-plating (12%) | Polyester painting | Anodizing | High phosphorous nickel-plating (12%) opt. AISI 316 (A4) | - Industry, general use. - Caustic soda. - Detergents. - Low alkaline solutions. |
| | Colour | Polished steel | Several available | Brown | Polished steel | |
| | Thickness | 20 µ | 60/80 µ | 15 µ | 20 µ | |
| | NN | DESCRIPTION | | | | APPLICATION FIELD |
| | | Body | Covers | Pistons | Shaft | |
|  | | High phosphorous nickel-plating (12%) | High phosphorous nickel-plating (12%) | Anodizing | High phosphorous nickel-plating (12%) opt. AISI 316 (A4) | - Industry, general use. - Caustic soda. - Detergents. - Low alkaline solutions. |
| | Colour | Polished steel | Polished steel | Brown | Polished steel | |
| | Thickness | 20 µ | 20 µ | 15 µ | 20 µ | |
| | TF TF | DESCRIPTION | | | | APPLICATION FIELD |
| | | Body | Covers | Pistons | Shaft | |
|  | | Hard Anodizing + PTFE coating | Anodizing + PTFE coating | Anodizing | High phosphorous nickel-plating (12%) opt. AISI 316 (A4) | - Industry, general use. - Low alkaline and low acid solutions. - Marine environments. - High temperatures. |
| | Colour | Blue | Blue | Brown | Polished steel | |
| | Thickness | Anodizing 50 µ PTFE 15 µ | Anodizing 50 µ PTFE 15 µ | 15 µ | 20 µ | |

HARD ANODIZING

Anodizing is an electrolytic process that produces anodic coating on aluminum, called alumine, with high thickness. Alumine is one of the most hard known materials, with resistance values up to 400-600 HV (45-65 HRC); properties and features of Hard Anodizing (alumine thickness 50 micron) are well know and appreciated both for mechanical and chemical resistance.

- **Best friction and corrosion resistance, best surface hardness, good thermic and electrical insulation.**

ELECTROLESS NICKEL-PLATING

Chemical nickel-plating is an electroless coating process that gives nickel layers at extremely constant thickness also on sharp angles, blind-holes, threads and grooves recess. During the process, nickel is combined with phosphor at a percentage of 12% (high-phospor). The obtained surface hardness is about 400-480 HV (45-55 HRC).

- **Best friction and corrosion resistance, best surface hardness, best external appearance similar to S.S., increased resistance to alkali and detergents in sanitary and food applications.**

POLYESTER PAINTING

Polyester painting is obtained through powder coatings on polarized parts, by means of light differences in electrical potentials. After applications, parts are baked in order to polymerize and let the painting be spread to avoid micro-porosity. The best elasticity can be obtained at 60/80 micron thickness; a satisfactory adhesion can be assured by sandblasting or brushing, and by special degreasing baths of the rough pieces to be treated.

- **Better corrosion resistance, protection against crashes, better external appearance and several available colours, resistance to chemicals.**

HARD ANODIZING + PTFE COATING

As further improvement of the hard anodizing on aluminium alloys, protective coating made of PTFE is used, known for its particular chemical and physical features. On these double treated surfaces, oxide hardness and low roughness (internal slipping parts) is summed to the chemical resistance and the excellent qualities as a thermic barrier of PTFE (external surfaces, subjected to corrosion).

- **Best corrosion resistance, protection against high temperatures, crashes, extreme resistance to chemicals and in marine environment.**

AIS I 316 (A4) STAINLESS STEEL SHAFT - OPTIONAL

AISI 316 (A4) Stainless Steel shaft, with its great corrosion resistance, is recommended for special applications such as: marine and chemical environments, food and pharmaceutical industry, high temperature applications.

STANDARD VERSION FEATURES

- Double lower drilling for valve fastening and centering, according to **ISO 5211-DIN 3337 Standards**.
- Double square lower female shaft key (starlike), according to **ISO 5211-DIN 3337 Standards** for assembly on valves with square key on line (0°) and diagonal key (45°).
- Solenoid connections according to **NAMUR VDI\VDE-3845 Standards**.
- Top drilling for accessories fastening, and upper shaft end according to **NAMUR VDI\VDE-3845 Standards**.
- Position indicator on request, enabling switch-box assembly on top.
- Running test and 100% seal test carried out with electronic equipment and certification of each individual product.
- Standard execution for temperatures from -20°C to +80°C (optional, special execution for extreme temperatures).
- According to **ATEX-94-9-CEE Standard** for explosive environment; STANDARD version actuator: II 2GD c Tmax = 95°C.
- According to **EN 15714-3** design and manufacture standard requirements.

DIMENSIONS - European sizes in millimetres

**I Series = 90°
Y Series = 120°
X Series = 180°**

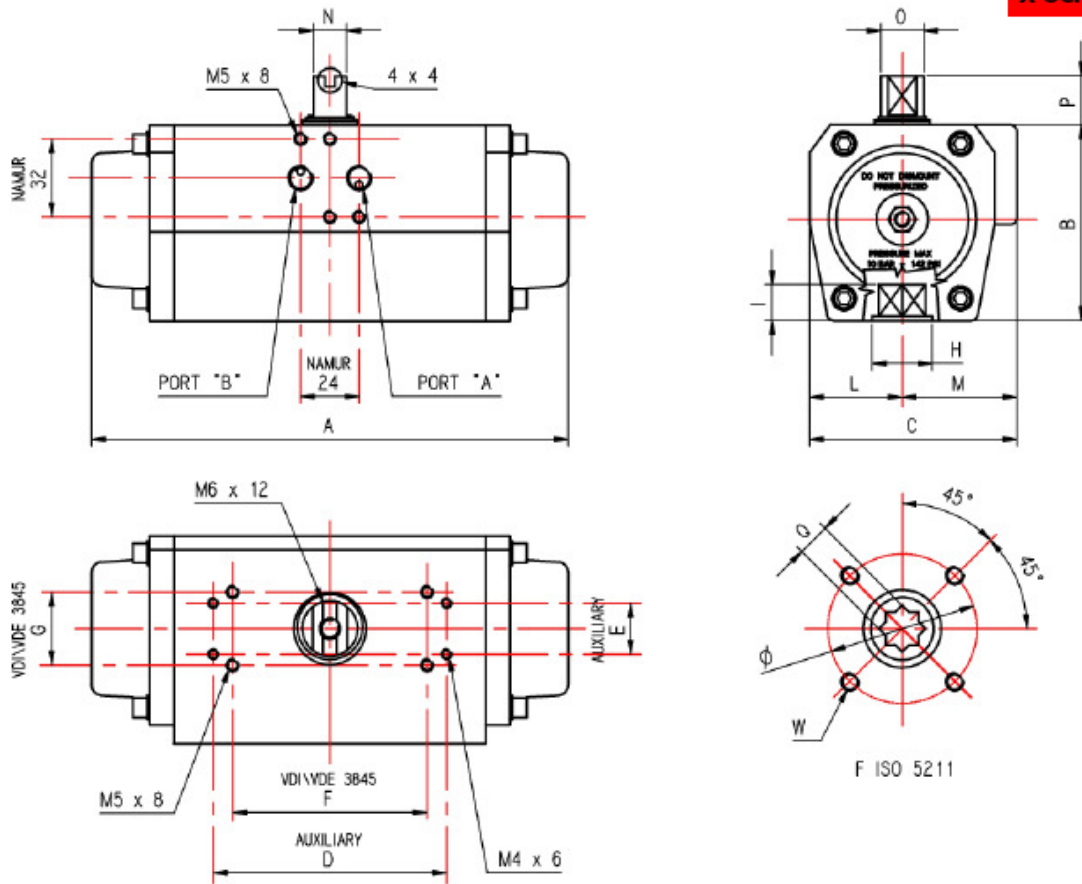

**Standard feeding connection 1/2" GAS – NPT for AP 240, 270, 330, 420
Special NAMUR plate on request**

| POSITION | TYPE | | | | | | | | | | | | | | | | |
|-----------------------|--------------|-------------------|-----------------------------|--|-------------------------------|--------------------|--------------------|--------------------|-------------------------------|--------------------|--------------------|--------------------|------------------------|---------------------|---------------------|--------------------|---------------------|
| | AP032 | AP042 | AP050 | AP063 | AP075 | AP085 | AP100 | AP115 | AP125 | AP145 | AP160 | AP180 | AP200 | AP240 | AP270 | AP330 | AP420 |
| A-90° | 117 | 160 | 138 | 155,5 | 210 | 228 | 280,5 | 310 | 362 | 390 | 462 | 474 | 575 | 604 | 685 | 850 | 934 |
| A-120° | 133 | 166 | 163 | 180 | 239 | 273 | 322 | 363 | 424 | - | - | - | - | - | - | - | - |
| A-180° | 175 | 211 | 196 | 214 | 297 | 332 | 398 | 451 | 518 | - | - | - | - | - | - | - | - |
| B | 45 | 57 | 67 | 83 | 100 | 110 | 125 | 142 | 155 | 175 | 196 | 220 | 240 | 298 | 332 | 414 | 534 |
| C | 48 | 60,5 | 75 | 86 | 94 | 104 | 120 | 134 | 141 | 163 | 176 | 196 | 220 | 300 | 352 | 400 | 521 |
| AUXILIARY D x E | - | | | | 105 x 22 | | | | 139 x 22 | | | | - | | | | |
| VDI/VDE 3845 F x G | 50x25 | | 80 x 30 | | | | | | 130 x 30 | | | | | | 200x50 | | |
| L | 22,5 | 27 | 33,5 | 38 | 42,5 | 49 | 55 | 63,5 | 69,5 | 80 | 88 | 98 | 110 | 150 | 166 | 190 | 249 |
| M | 25,5 | 33,5 | 41,5 | 48 | 51,5 | 55 | 65 | 70,5 | 71,5 | 83 | 88 | 98 | 110 | 150 | 166 | 210 | 272 |
| Port A Port B DIN 259 | 1/8" GAS NPT | | | | 1/4" GAS NPT | | | | | | 1/2" GAS NPT | | | | | | |
| N x O | 8 x 12 | | | 14 x 18 | | | | 27 x 36 | | | | 32 x 42 | | 32 x 60 | | 55 x 80 | |
| P | 20 | | | | 30 | | | | 50 | | | | 80 | | | | |
| Q x I | 9 x 10 | 9 x 10 11 x 13 | 9 x 10 11 x 13 | 9 x 10 11 x 13 14 x 16 | 11 x 13 14 x 16 17 x 20 | 14 x 16 17 x 20 | 17 x 20 22 x 25 | 17 x 20 22 x 25 | 17 x 20 22 x 25 27 x 30 | 22 x 25 27 x 30 | 22 x 25 27 x 30 | 27 x 30 36 x 39 | 27 x 30 36 x 39 | 36 x 39 46 x 50 | 36 x 39 46 x 50 | 46 x 50 55 x 60 | 55 x 60 75 x 80 |
| F ISO 5211 | F03 F04 | F04 F03/05 | F03 F04 F03/05 F05 | F03/05 F3/5/7 F04 F05 F05/07 | F04 F05/07 | F05/07 | F07/10 F5/7/10 | F07/10 | F07/10 F12 | F10/12 | F10/12 | F10/12 F14 | F10/12 F14 (F16) | (F12) F14 F16 | (F12) F14 F16 | F16 F25 | (F16) F25 F30 |

| POSIZIONE | F ISO 5211 | | | | | | | | | | | | |
|-----------|-------------------------|--------------|------------------------|--------------|-------------------------|---|----------------------------|------------------------------|-----------------|-------------------------|-------------------|-----------------|-----------------|
| | F03 | F04 | F03/05 | F05 | F05/07 | F5/7/10 | F07/10 | F10/12 | F12 | F14 | F16 | F25 | F30 |
| Ø (W) | 36 (M5x8) | 42 (M5x8) | 36 (M5x8) 50 (M6x9) | 50 (M6x9) | 50 (M6x9) 70 (M8x12) | 50 (M6x9) 70 (M8x12) 102 (M10x15) | 70 (M8x12) 102 (M10x15) | 102 (M10x15) 125 (M12x18) | 125 (M12x18) | 140 (M16x24) | 165 (M20x30) | 254 (M16x24) | 298 (M20x35) |
| H | 25 escluso AP 032 | 30 | 25 | 35 | 35 (AP085=40) | 40 | 55 | 75 | 75 | 100 (AP270 = 104) | 130 AP200 = 85 | 200 | 200 |

CONSTRUCTION PARTS - SPECIFICATIONS

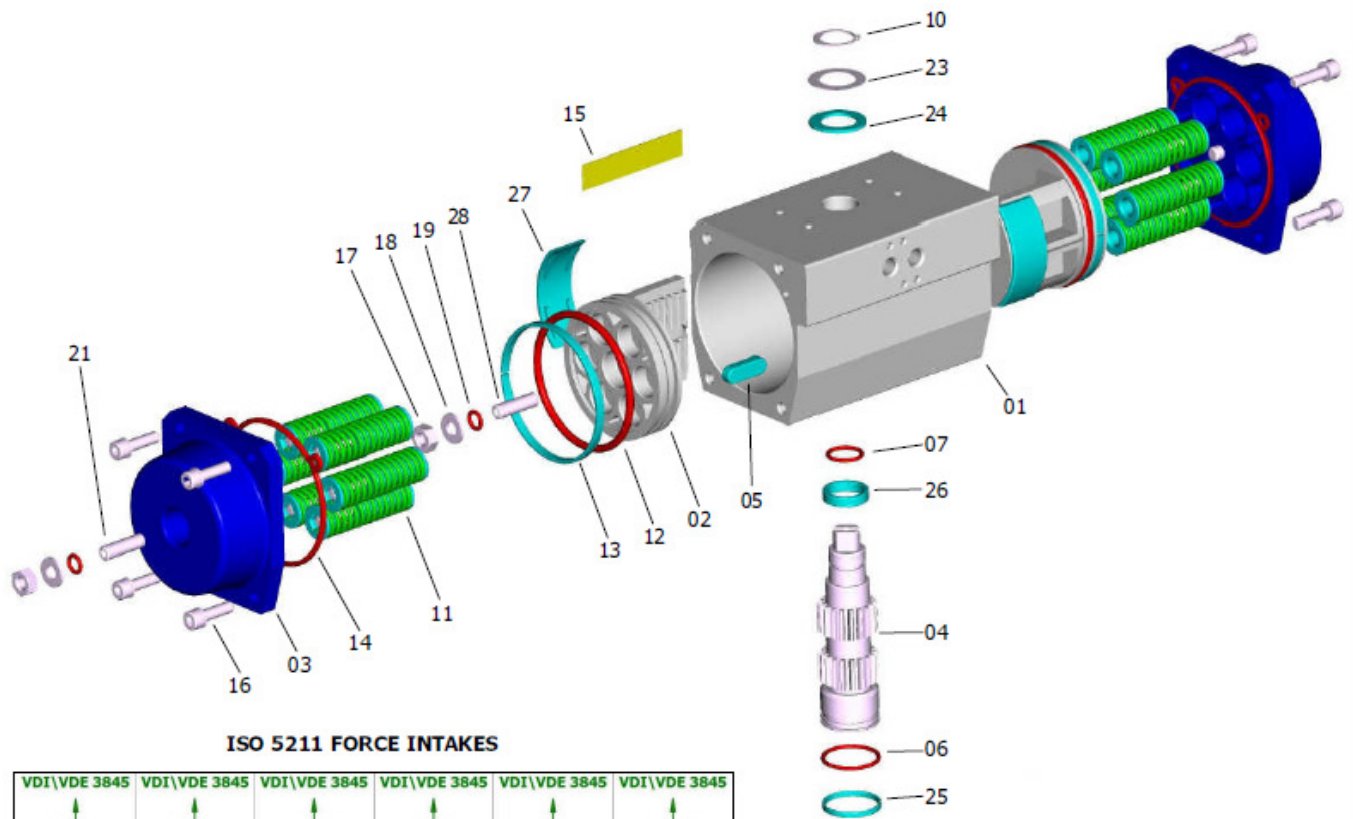

ISO 5211 FORCE INTAKES

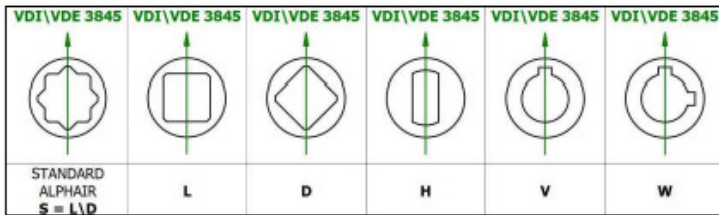

| PART | QUANTITY | DESCRIPTION | MATERIAL | SPECIFICATION | PROTECTION |
|------|----------|------------------------|---|--|------------|
| 1 | 1 | Body | Extruded aluminium alloy | ASTM 6063 T6 | A - N - TF |
| 2 | 2 | Piston | Aluminium alloy | ASTM B179 - DIN1725/5 | A |
| 3 | 2 | Cover | Aluminium alloy | ASTM B179 - DIN1725/5 | N - V - TF |
| 4 | 1 | Shaft | Carbon steel optional S.S. AISI 316 (A4) | ASTM A105 optional S.S. AISI 316 (A4) | N |
| 5 * | 2 | Antiejection key | Acetalic resin - PA66 - PA66 | | |
| 6 * | 1 | Lower shaft O-Ring | NBR - Viton - Silicone | | |
| 7 * | 1 | Upper shaft O-Ring | NBR - Viton - Silicone | | |
| 10 * | 1 | Seeger ring | Carbon steel | | N |
| 11 | 0-12 | Spring cartridge | Carbon steel, PA 66, S.S. | C-98 | V |
| 12 * | 2 | Piston O-Ring | NBR - Viton - Silicone | | |
| 13 * | 2 | Piston head bearing | Acetalic resin - PA66 - PA66 | | |
| 14 * | 2 | Cover gasket | NBR - Viton - Silicone | | |
| 15 | 1 | Nameplate | Aluminium | | |
| 16 | 8-16 | Cover fastening screw | Stainless Steel | AISI 304 (A2) | |
| 17 | 4 | Nut | Stainless Steel | AISI 304 (A2) | |
| 18 | 4 | Washer | Stainless Steel | AISI 304 (A2) | |
| 19 * | 4 | O-Ring | NBR - Viton - Silicone | | |
| 21 | 2 | Cover dowel | Stainless Steel | AISI 304 (A2) | |
| 23 * | 1 | Shaft thrust washer | Stainless Steel | AISI 304 (A2) | |
| 24 * | 1 | Antifriction washer | Acetalic resin - PA66 - PA66 | | |
| 25 * | 1 | Lower shaft pilot ring | Acetalic resin - PA66 - PA66 | | |
| 26 * | 1 | Upper shaft pilot ring | Acetalic resin - PA66 - PA66 | | |
| 27 * | 2-4 | Piston bearing | Acetalic resin - PA66 - PA66 | | |
| 28 | 2 | Piston dowel | Stainless Steel | AISI 304 (A2) | |

* Standard NBR spare parts set - Special HIGH Temperatures VITON - Special LOW Temperatures SILICONE

Protection

A = Anodizing N = chemical Nickel-plating V = Painting TF = Anodizing+PTFE