

2/2- and 3/2-way Ball Valve with manual override, plastic body, DN10-50



Type 2657 can be combined with ...



Typ 2050

Pneumatic actuator



Type 3003

Electric actuator

- Application for aggressive media
- High flow-rate
- Safe blocked union nuts with Dual Block® Technology ¹⁾

2/2- and 3/2-way ball valves with manual override in plastic for separating medium flow. There are different body versions and materials can be ordered to suit various applications.

Special feature

The ball valves are equipped with the so-called Dual Block® Technology. This system serves as a safety device for the union nuts. It prevents these separating during operation.

Technical Data

Body material	PVC-U, PP (PVDF, PVC-C on request)
Seal material	PTFE / EPDM, PTFE / FKM
Media temperature	(see diagram on p2)
PVC-U	0 to +60°C
PP	+10 to +80°C
PVDF	0 to +120°C
Port connection	
PVC-U	True union
PP, (PVDF on request)	Fusion spigot
Operating pressure	0 - 10bar; 0 - 16bar

¹⁾ Dual Block® Technology is a registered trademark of FIP - Formatura Iniezione Polimeri S.p.A

Pressure Temperature Chart

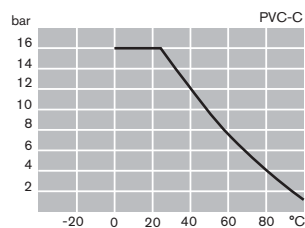
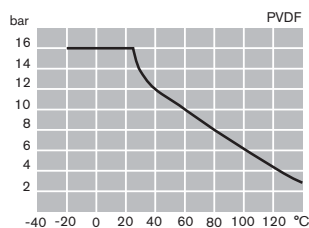
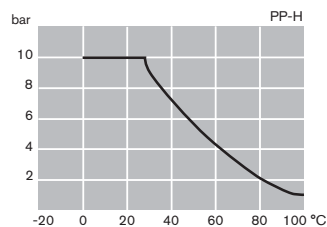
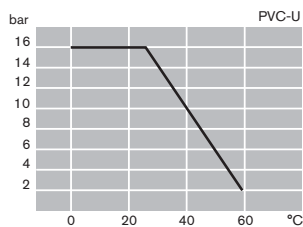

Ordering chart 2/2-way Ball Valve (further versions on request)

Orifice [mm]	Port connection Ø [mm]	k_{vs} value for water [m ³ /h]	Pressure range PVC-U, PVDF [bar]	Pressure range PP [bar]	Item no. true union PVC	Item no. fusion spigot PP
Seal material PTFE/EPDM						
10	16	4.8	0-16	0-10	176 462	176 469
15	20	12	0-16	0-10	176 463	176 470
20	25	23	0-16	0-10	176 464	176 471
25	32	46	0-16	0-10	176 465	176 472
32	40	66	0-16	0-10	176 466	176 473
40	50	105	0-16	0-10	176 467	176 474
50	63	204	0-10	0-10	176 468	176 475
Seal material PTFE/FKM						
10	16	4.8	0-16	0-10	176 476	176 483
15	20	12	0-16	0-10	176 477	176 484
20	25	23	0-16	0-10	176 478	176 485
25	32	46	0-16	0-10	176 479	176 486
32	40	66	0-16	0-10	176 480	176 487
40	50	105	0-16	0-10	176 481	176 488
50	63	204	0-10	0-10	176 482	176 489

Ordering chart 3/2-way Ball Valve, PVC (further versions on request)

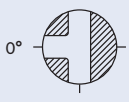
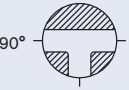
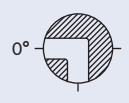
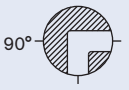
Switched position	Orifice [mm]	Port connection Ø [mm]	k_{vs} value for water [m ³ /h]	Pressure range PP [bar]	Item no. seal material EPDM	Item no. seal material FKM	
T1  0°	10	16	1.5	0-16	209 890	186 022	
	15	20	2.1	0-16	209 891	186 023	
	20	25	5.7	0-16	209 892	186 024	
	25	32	8.4	0-16	209 893	186 025	
	90° 	32	40	16.2	0-16	209 894	186 026
		40	50	19.8	0-16	209 895	186 027
L4  0°	50	63	37.2	0-10	209 896	186 028	
	10	16	2.8	0-16	209 897	186 015	
	15	20	4.3	0-16	209 898	186 016	
	20	25	9.0	0-16	209 899	186 017	
	25	32	15.9	0-16	209 900	186 018	
	90° 	32	40	28.5	0-16	202 689	186 019
		40	50	37.2	0-16	209 901	186 020
	50	63	67.2	0-10	209 902	186 021	

Dimensions [mm]

2/2-way version

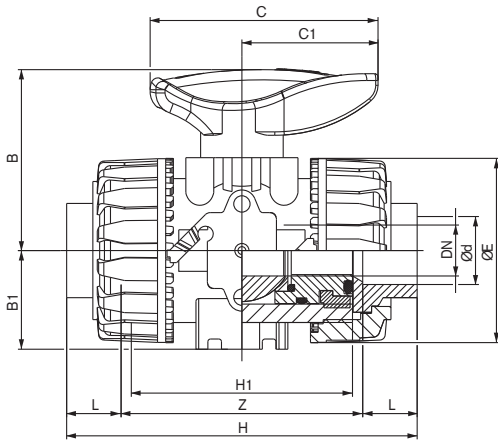

Ød	DN	L	Z	H	H1	ØE	B	B1	C	C1	Weight [g]
16	10	14	75	103	65	54	54	29	67	40	215
20	15	16	71	103	65	54	54	29	67	40	205
25	20	19	77	115	70	65	65	34.5	85	49	330
32	25	22	84	128	78	73	69.5	39	85	49	438
40	32	26	94	146	88	86	82.5	46	108	64	693
50	40	31	102	164	93	98	89	52	108	64	925
63	50	38	123	199	111	122	108	62	134	76	1577

3/2-way version

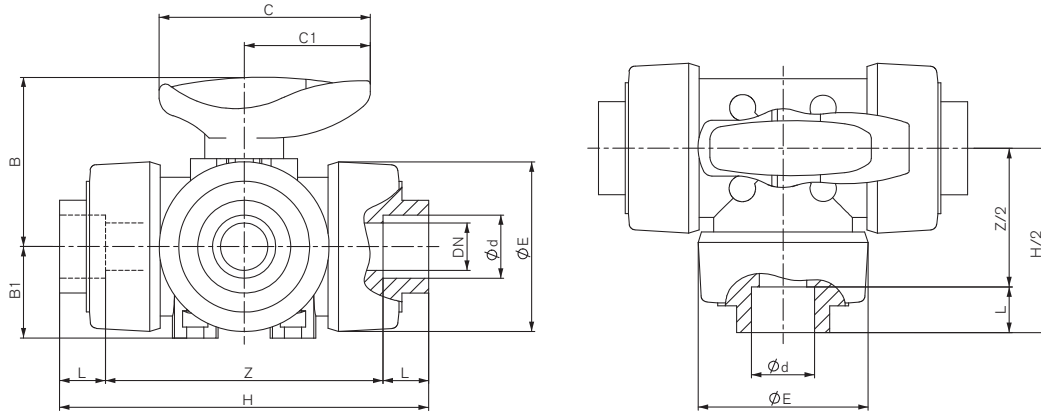

Ød	DN	L	Z	H	ØE	B	B1	C	C1	Weight [g]
16	10	14	90	118	54	54	29	67	40	310
20	15	16	86	118	54	54	29	67	40	310
25	20	19	107	145	65	65	34.5	85	49	550
32	25	22	116	160	73	69.5	39	85	49	790
40	32	26	136.5	188.5	86	82.5	46	108	64	1275
50	40	31	157	219	98	89	52	108	64	1660
63	50	38	190.5	266.5	122	108	62	134	76	2800

To find your nearest Burkert facility, click on the orange box

www.burkert.com

In case of special application conditions,
please consult for advice

Subject to alteration.
© Christian Bürkert GmbH & Co. KG

0909/5_EU-en_00891693